

**RULES AND REGULATIONS FOR
HICKORY TELEPHONE COMPANY'S ADSL**
(Effective 6/1/06)

1. Digital Subscriber Line Access Services

Asymmetric Digital Subscriber Line Access Services provide transmission services over local exchange service facilities that can be used for simultaneous voice and data communications. Service is provided, where available, between customer designated premises and designated Telephone Company Serving Wire Centers.

1.1 Asymmetric Digital Subscriber Line Access Service

1.1.1 General

Asymmetric Digital Subscriber Line (ADSL) Access Service enables data traffic generated by a customer-provided modem to be transported to a DSL Access Service Connection Point using the Telephone Company's local exchange service facilities. A DSL Access Service Connection Point is an interconnection point designated by the Telephone Company at which the customer may interconnect its ADSL Access Service provided by the Telephone Company under this tariff or its wireline broadband Internet transmission service provided on a non-tariffed, common carrier basis with the tariffed, interstate access services described below. The DSL Access Service Connection Point aggregates ADSL Access Service and/or wireline broadband Internet transmission service data traffic from and to suitably equipped Telephone Company Serving Wire Centers (SWCs). The DSL Access Service Connection Point may be located within the operating territory of the Telephone Company for connections to Special Access Services, Frame Relay Access Service or Asynchronous Transfer Mode Cell Relay Access Service (ATM-CRS) or, in the operating territory of another telephone company for connections to special access or frame relay access services, provided both telephone companies agree to such an arrangement.

When both the ADSL-equipped SWC and its associated DSL Access Service Connection Point are located within the Telephone Company's operating territory, the customer's ADSL Access Service must be connected to a single telecommunications service provider's (TSP's) customer designated premises using the Telephone Company's Special Access Services, Frame Relay Access Service or ATM-CRS provided under this tariff.

When both the ADSL-equipped SWC from which the Telephone Company provides local exchange and exchange access services and its associated DSL Access Service Connection Point are located in the operating territory of another telephone company, the customer's ADSL Access Service must be connected to a single TSP's customer designated premises using either equivalent special access service or frame relay access service provided by the distant telephone company.

**RULES AND REGULATIONS FOR
HICKORY TELEPHONE COMPANY'S ADSL**

1. Digital Subscriber Line Access Services (Cont'd)

1.1 Asymmetric Digital Subscriber Line Access Service (Cont'd)

1.1.1 General (Cont'd)

When the ADSL-equipped SWC is located within the Telephone Company's operating territory and its associated DSL Access Service Connection Point is located in the operating territory of another telephone company, the customer's ADSL Access Service must be connected to a single TSP's customer designated premises using either equivalent frame relay access service provided by the distant telephone company, or a combination of DSL Extended Transport provided by the Telephone Company under this tariff and equivalent special access service provided by the distant telephone company.

ADSL Access Service is available as two service options, i.e., ADSL Voice-Data and ADSL Data-Only.

- (A) The ADSL Voice-Data option provides transmission of data signals at a peak data transmission speeds of 512 kbps upstream and 6 Mbps downstream using the Telephone Company's existing local exchange service line. This option may be used for simultaneous voice and data communications.

- (B) The ADSL Data-Only option provides transmission of data signals at peak transmission speeds of 512 kbps upstream and 6 Mbps downstream using the Telephone Company's existing local exchange facilities. This option does not provide the ability to transmit voice communications.

RULES AND REGULATIONS FOR HICKORY TELEPHONE COMPANY'S ADSL

1. Digital Subscriber Line Access Services (Cont'd)

1.1 Asymmetric Digital Subscriber Line Access Service (Cont'd)

1.1.1 General (Cont'd)

A generic view of how ADSL Access Service could be interconnected with a TSP's network is depicted in the figure following. In the first example, the customer's ADSL-equipped Serving Wire Center and associated DSL Access Service Connection Point are located in the same office within the Telephone Company's operating territory. The ADSL Access Service customer orders ADSL Access Service pursuant to the provisions specified in this section. The ADSL Access Service customer's TSP orders Special Access Services, Frame Relay Access Service and/or Asynchronous Transfer Mode Cell Relay Access Service (ATM-CRS) pursuant to the provisions specified in this document to connect its customer designated premises to the DSL Access Service Connection Point.

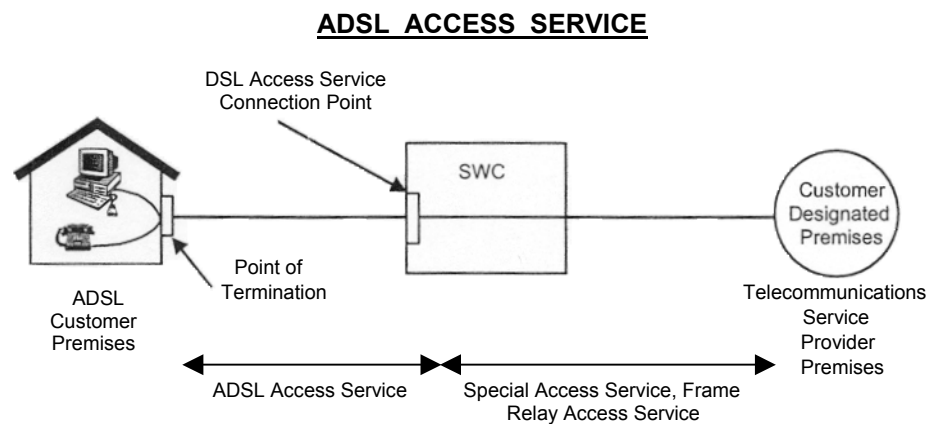

RULES AND REGULATIONS FOR HICKORY TELEPHONE COMPANY'S ADSL

1. Digital Subscriber Line Access Services (Cont'd)

1.1 Asymmetric Digital Subscriber Line Access Service (Cont'd)

1.1.1 General (Cont'd)

In the example shown below, the DSL Access Service Connection Point is located outside the Telephone Company's operating territory. The ADSL Access Service customer orders ADSL Access Service pursuant to the provisions specified in this section. In order to connect its customer designated premises to the DSL Access Service Connection Point using special access service, the ADSL Access Service customer's TSP orders DSL Extended Transport from the Telephone Company as specified in this section and equivalent special access service from the distant telephone company.

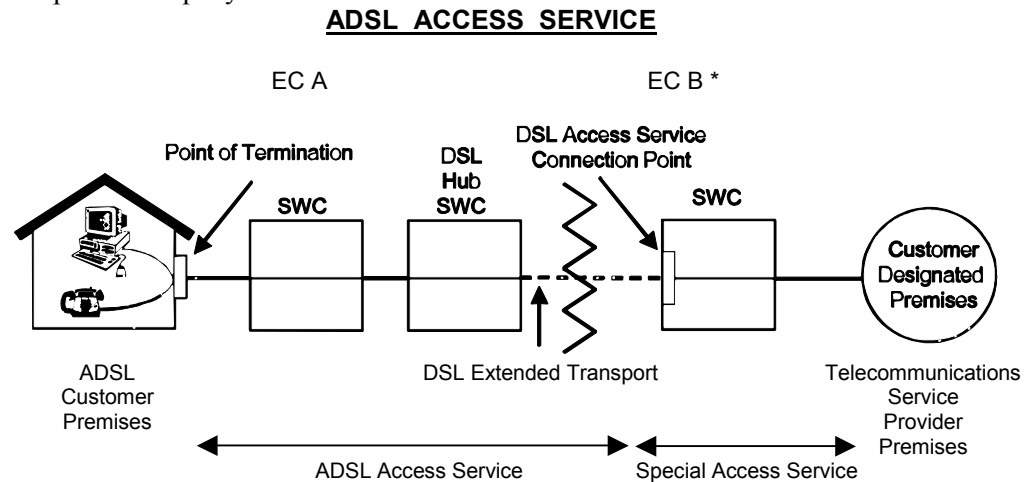

* If EC B is a non-NECA company, the application of their charges will depend on their access tariff.

1.1.2 Limitations

ADSL Access Service is available as two service options as described above. ADSL Access Service is at a maximum upstream speed of 512 kbps (i.e., from the customer's equipment up to the DSL Access Service Connection Point) and a maximum downstream speed of 6 Mbps (i.e., from the DSL Access Service Connection Point down to the customer's equipment). These peak speeds are not guaranteed by the Telephone Company due to factors that may affect the actual speeds delivered, including the ADSL Access Service customer's distance from the Telephone Company Serving Wire Center, condition of the existing local exchange service facilities, and any capacity limitations in the TSP's network design.

**RULES AND REGULATIONS FOR
HICKORY TELEPHONE COMPANY'S ADSL**

1. Digital Subscriber Line Access Services (Cont'd)

1.1 Asymmetric Digital Subscriber Line Access Service (Cont'd)

1.1.2 Limitations (Cont'd)

The Telephone Company does not provide customer premises equipment (CPE) in conjunction with the ADSL Access Service offering.

ADSL Access Service may not be used in conjunction with multi-point Special Access Service Configurations as described in this document.

ADSL Access Service will be furnished where suitable facilities exist as determined by the Telephone Company. The Telephone Company will identify its ADSL-equipped Serving Wire Centers, DSL Access Service Connection Point Serving Wire Centers, and, if applicable, DSL Transport Hub Serving Wire.

ADSL Access Service will be provided over existing Telephone Company local exchange service facilities. When the customer orders the ADSL Voice-Data option, the rates and regulations for ADSL Access Service are in addition to any rates and regulations that apply for the associated local exchange service line provided under the terms and conditions in the Telephone Company's general and/or local exchange service tariffs. The Telephone Company will automatically disconnect the ADSL Access Service Voice-Data option when the associated local exchange service line is disconnected for any reason.

**RULES AND REGULATIONS FOR
HICKORY TELEPHONE COMPANY'S ADSL**

1. Digital Subscriber Line Access Services (Cont'd)

1.1 Asymmetric Digital Subscriber Line Access Service (Cont'd)

1.1.3 Undertaking of the Telephone Company

The Telephone Company will provide ADSL Access Service at rates and charges as set forth in this document:

- (A) The Telephone Company will determine if the associated local exchange service line or facilities are suitable for use with the ADSL Access Service option ordered by the customer. Service will not be provided on lines that the Telephone Company determines are not suitable for ADSL Access Service or on lines that produce interference with other services provided by the Telephone Company.
- (B) The Telephone Company, after determining if the facilities are suitable for ADSL Access Service, will notify the customer if any additional CPE is necessary to support ADSL Access Service.
- (C) The Telephone Company will provision and maintain ADSL Access Service from the DSL Access Service Connection Point to the Point of Termination at the ADSL Access Service customer's premises, except as provided for in this document.
- (D) The Telephone Company will notify the ADSL Access Service customer's TSP when DSL Extended Transport, as described in this document, is required.

1.1.4 Obligations of the Customer

In addition to the regulations described in other sections of this document, the following provisions apply to ADSL Access Service:

- (A) The customer is responsible for providing the Telephone Company with the necessary information to provision ADSL Access Service (e.g., customer name, telephone number and premises address; billing name and address when different from the customer name and premise address; its internet Protocol (IP) address; and the contact name and telephone number of the TSP with which the customer's ADSL Access Service will interconnect)].
- (B) The customer is responsible for providing and maintaining all required customer provided equipment (CPE), which is compatible with ADSL Access Service.

**RULES AND REGULATIONS FOR
HICKORY TELEPHONE COMPANY'S ADSL**

1. Digital Subscriber Line Access Services (Cont'd)

1.1 Asymmetric Digital Subscriber Line Access Service (Cont'd)

1.1.5 Rate Regulations

This section contains the regulations governing the rates and charges that apply for ADSL Access Service.

(A) Minimum Period

The minimum period for which ADSL Access Service is provided to a customer and for which charges are applicable is one month.

(B) Moves

A move involves a change in the physical location of one of the following:

- The Point of Termination at the ADSL Access Service customer designated premises
- The ADSL Access Service customer-designated premises

(C) Temporary Suspension of Service

When the associated local exchange service line over which the ADSL Voice-Data option is provided is temporarily suspended, the ADSL Access Service and one-half of the ADSL Line Charge monthly rate will be temporarily suspended for the time period that the associated local exchange service is suspended.

(D) DSL Extended Transport

DSL Extended Transport is required when: 1) the Telephone Company providing ADSL Access Service locates its DSL Access Service Connection Point outside its operating territory in the operating territory of another telephone company and 2) the ADSL Access Service customer's TSP connects its customer designated premises to the DSL Access Service Connection Point using Special Access Service preceding, or equivalent special access service provided by the distant telephone company.

DSL Extended Transport provides the TSP with a virtual circuit path capable of supporting a peak data speed of up to 1.544 Mbps between a Telephone Company-designated DSL Transport Hub and its associated DSL Access Service Connection Point location. The Telephone Company must designate at least one DSL Transport Hub SWC location within its operating territory when it locates a DSL Access Service Connection Point outside its operating territory. The DSL Transport Hub aggregates ADSL and/or SDSL Access Services data traffic within the operating territory of the Telephone Company providing the DSL Access Service.

**RULES AND REGULATIONS FOR
HICKORY TELEPHONE COMPANY'S ADSL**

1. Digital Subscriber Line Access Services (Cont'd)

1.1 Asymmetric Digital Subscriber Line Access Service (Cont'd)

1.1.5 Rate Regulations (Cont'd)

(D) DSL Extended Transport (Cont'd)

DSL Extended Transport is used to transmit ADSL and/or SDSL data traffic. The TSP is responsible for determining and ordering the number of DSL Extended Transport virtual circuit paths it requires to meet its end users' data transmission needs. The TSP must place an order for at least one DSL Extended Transport virtual circuit path, where required, when it places the order for Special Access Service (or equivalent special access service) to connect its customer designated premises to the DSL Access Service Connection Point. An Access Order Charge applies per order for the installation of DSL Extended Transport.

DSL Extended Transport is available between a DSL Transport Hub SWC and the associated DSL Access Service Connection Point SWC located within the United States. It is also available between a DSL Transport Hub SWC and a cross border connection point located within the United States when the Telephone Company has located its designated DSL Access Service Connection Point in Canada.

When the DSL Access Service Connection Point is located in Canada, DSL Extended Transport will be furnished by the Telephone Company to a cross border connection point located in the United States. DSL Extended Transport from the cross border connection point to the DSL Access Service Connection Point will be provided by the Canadian telephone company. The Telephone Company will work cooperatively with the TSP and Canadian Telephone Company for the provisioning of DSL Extended Transport in Canada. Rates and regulations defined in this section only apply to that portion of the service between the DSL Transport HUB and the cross border connection point.

**RULES AND REGULATIONS FOR
HICKORY TELEPHONE COMPANY'S ADSL**

1. Digital Subscriber Line Access Services (Cont'd)

1.1 Asymmetric Digital Subscriber Line Access Service (Cont'd)

1.1.5 Rate Regulations (Cont'd)

(D) DSL Extended Transport (Cont'd)

(1) Mileage Measurement

- (a) The mileage to be used to determine the monthly charges for each DSL Extended Transport virtual circuit path is calculated using the airline distance between each DSL Transport Hub and its associated DSL Access Service Connection Point when both locations are within the United States. To determine the applicable monthly charges, first compute the mileage using the V&H coordinates method. When the calculation results in a fraction of a mile, always round up to the next whole mile before determining the total mileage and applying the rates. Once the total mileage for each path is determined, multiply the number of miles times the DSL Extended Transport per mile rates.

The following example is an illustrative model, only provided for the purpose of clarification. Actual charges will vary, dependent upon the effective DSL Extended Transport per mile rates.

Example:

- TSP orders two DSL Extended Transport paths between a DSL Transport Hub SWC and the associated DSL Access Service Connection Point SWC. Both SWCs are located within the United States.
- Total mileage between the SWCs is calculated at 28.4 miles.

Monthly charges for DSL Extended Transport are determined as follows:

- Fractional mileage rounded up to the next whole mile equals 29 miles.
- First 25 miles x \$0.00 per mile equals \$0.00 per path.
- Next four miles x \$15.31 per mile equals \$61.24 per path.
- Total mileage charges for DSL Extended Transport in this example equal \$122.48 per month (i.e., \$61.24 x two paths).

**RULES AND REGULATIONS FOR
HICKORY TELEPHONE COMPANY'S ADSL**

1. Digital Subscriber Line Access Services (Cont'd)

1.1 Asymmetric Digital Subscriber Line Access Service (Cont'd)

1.1.5 Rate Regulations (Cont'd)

(D) DSL Extended Transport (Cont'd)

(1) Mileage Measurement (Cont'd)

(b) The mileage to be used to determine the monthly charges for each DSL Extended Transport virtual circuit path between a DSL Transport Hub and a cross border connection point is specified below. To calculate the monthly charges for each path, multiply the number of miles between the DSL Transport Hub and the cross border connection point times the DSL Extended Transport per mile rates. The portion of the DSL Extended Transport furnished from the cross border connection point to the DSL Access Service Connection Point is the responsibility of the TSP and is not covered in this document.

(i) The number of miles to be used for rating DSL Extended Transport provided in this document between Ketchikan Public Utilities DSL Transport Hub SWC and the Garnet Point, AK cross border connection point is 60 miles.

(E) Rate Categories

There are three types of rates and charges applicable to ADSL Access Service. These are a monthly rate, a nonrecurring charge and a network reconfiguration charge.

The monthly rate for the ADSL Line Charge applies each month or fraction thereof for each ADSL Voice-Data option and ADSL Data-Only option ordered by the customer. The monthly rate for DSL Extended Transport applies each month or fraction thereof for each 1.544 Mbps virtual circuit path.

A nonrecurring charge applies for each ADSL Voice-Data option and ADSL Data-Only option ordered by the customer for the installation of ADSL Access Service. The nonrecurring charge will be waived for each new ADSL Voice-Data option and ADSL Data-Only option Access Line ordered when the customer commits to retain ADSL Access Line for a minimum period of 12 months following installation of service. If the ADSL Access Line is disconnected for any reason prior to the end of the 12-month minimum commitment period other than for ADSL option conversions as described below, the Telephone Company will bill the customer an amount equal to the waived nonrecurring charge.

**RULES AND REGULATIONS FOR
HICKORY TELEPHONE COMPANY'S ADSL**

1. Digital Subscriber Line Access Services (Cont'd)

1.1 Asymmetric Digital Subscriber Line Access Service (Cont'd)

1.1.5 Rate Regulations (Cont'd)

(E) Rate Categories (Cont'd)

All changes to existing ADSL Access Service (e.g., a change of TSP and restoral of the ADSL Access Service following a disconnect for non-payment of charges and/or a disconnect of the associated local exchange service line for any reason), other than changes involving ADSL option conversions, DSL network reconfigurations and administrative activities, as described below, will be treated as a discontinuance of the existing service and an installation of a new service. A nonrecurring installation charge will apply per ADSL Access Service line for this work activity.

The Telephone Company will not bill the waived nonrecurring charge on an ADSL option conversion (i.e., replacing ADSL Voice-Data with ADSL Data-Only, or vice versa) when the customer provides the Telephone Company with 30 days notice of its intent to convert and commits to retain the new ADSL Access Service option for a new minimum 12-month period.

A DSL Network Reconfiguration Charge applies when the ADSL Access Service customer's TSP requests the Telephone Company to modify the Telephone Company's network to: 1) accommodate a change in the ADSL Access Service customer's existing IP address or 2) limit the data speed delivered over the customer's existing ADSL Access Service line. This charge applies for each request per ADSL Access Service line. The Telephone Company will bill the DSL Network Reconfiguration Charge to the ADSL Access Service customer's TSP.

The following administrative changes will be made without charge to the customer:

- Change of customer premises address when the change of address is not a result of a physical relocation of equipment,
- Change in billing data (name, address or contact name or telephone),
- Change of billing account number,
- Change of agency authorization that requires no changes to the Telephone Company's network,
- Change of customer contact name or telephone number, and
- Change of jurisdiction.

Rates and charges for ADSL Access Service are as set forth in this document, when the customer purchases ADSL Access Service under the DSL Access Services Wholesale Rate Plan as described in this document. The DSL Network Reconfiguration Charge is as set forth in this document. The rate for DSL Extended Transport is as set forth in this document.

**RULES AND REGULATIONS FOR
HICKORY TELEPHONE COMPANY'S ADSL**

1. Digital Subscriber Line Access Services (Cont'd)

1.2 DSL Access Services Wholesale Rate Plan

1.2.1 DSL WRP Term Plan

(A) Description

The DSL WRP Term Plan provides the customer with reduced rates based on the length of the customer's term commitment and its selected pricing option. The DSL WRP Term Plan is available for term lengths of one or three years with a choice of two pricing options. As used in this section, a WRP Serving Wire Center (WRP SWC) denotes an ADSL and/or SDSL equipped host or standalone end office at which the customer elects to make a term plan commitment. The Telephone Company will establish a separate term plan commitment for each WRP SWC identified in the customer's order.

When the customer subscribes to a DSL WRP Term Plan, all in-service ADSL and/or SDSL Access Service lines provided out of and subsequently installed at the WRP SWC, including any lines served by a remote SWC that subtends an associated host SWC covered by a term plan commitment, will be billed the rates and charges specified in this document, following, for the length of the term commitment. In addition to the applicable ADSL and/or SDSL Line Charges, the customer will be billed a recurring monthly DSL WRP Term Plan Charge for each WRP SWC, as specified in this document following, based on its selected pricing option.

If the Telephone Company decreases the rates during the term of a commitment period, the decreased rates will automatically be applied for the remainder of the current commitment period.

At the end of the DSL WRP Term Plan, the customer may elect to establish a new DSL WRP Term Plan commitment, convert to the rates available under the DSL WRP Monthly Plan, or discontinue service. If the customer does not make an election by the end of the DSL WRP Term Plan, the rates for all in service ADSL and/or SDSL Access Service lines will automatically be converted to the rates available under the DSL WRP Monthly Plan. An Access Order Charge will not apply to any election made by the customer at the end of the DSL WRP Term Plan.

A DSL WRP Term Plan is subject to payment for early termination as described below.

**RULES AND REGULATIONS FOR
HICKORY TELEPHONE COMPANY'S ADSL**

1. Digital Subscriber Line Access Services (Cont'd)

1.2 DSL Access Services Wholesale Rate Plan (Cont'd)

1.2.1 DSL WRP Term Plan (Cont'd)

(B) Upgrades in DSL WRP Term Plan

A customer may terminate a DSL WRP Term Plan without the application of a termination liability charge when the customer replaces its original DSL WRP Term Plan commitment with a new DSL WRP Term Plan commitment provided the length and pricing option of the new DSL WRP Term Plan commitment is equal to or greater than the length and pricing option of the original DSL WRP Term Plan commitment. An Access Order Charge will not apply when the customer replaces an existing DSL WRP Term Plan commitment with a new DSL WRP Term Plan commitment under this provision.

(C) Termination without Liability

A customer may terminate a DSL WRP Term Plan commitment without the application of a termination liability charge if the Telephone Company increases the DSL WRP Term Plan rates during the term of the existing commitment. The customer has 90 days following such rate increase to notify the Telephone Company in writing of its intent to terminate its DSL WRP Term Plan commitment under this section; otherwise, the increased rates will apply for the remainder of the commitment period.

(D) Termination with Liability

If the customer elects to terminate its DSL WRP Term Plan (s) prior to the end of the commitment period for any reason other than specified in (B) or (C), above, a termination liability charge will apply. For each DSL WRP Term Plan terminated prior to the end of the commitment period, the Telephone Company will bill the customer a charge equal to the monthly DSL WRP Term Plan Charge for its selected pricing option multiplied by the number of months remaining in each commitment period.

DSL WRP Monthly Plan rates will apply to all in-service ADSL and/or SDSL Access Lines following the early termination of a DSL WRP Term Plan.

(E) DSL Volume Pricing Commitment Plan

The DSL Volume Pricing Commitment Plan (DSL VPCP) is an optional pricing plan that provides the DSL WRP Term Plan customer with a discount applied against the monthly ADSL and/or SDSL Line Charges for lines served by a WRP SWC at which the customer made a DSL WRP Term Plan commitment. In order to subscribe to and retain the DSL VPCP, the customer

**RULES AND REGULATIONS FOR
HICKORY TELEPHONE COMPANY'S ADSL**

1. Digital Subscriber Line Access Services (Cont'd)

1.2 DSL Access Services Wholesale Rate Plan (Cont'd)

1.2.1 DSL WRP Term Plan (Cont'd)

(E) DSL Volume Pricing Commitment Plan (Cont'd)

must have at least one existing DSL WRP Term Plan commitment with the Telephone Company. The amount of the DSL VPCP discount applied is based on the level of the monthly volume commitment selected by the DSL WRP Term Plan customer. The DSL VPCP commitment period is for one year. The DSL VPCP discount does not apply to any rate elements other than the monthly recurring DSL WRP Term Plan Line Charges.

The customer will select its monthly volume commitment level based on its projected number of monthly in-service ADSL and SDSL Access Service lines served by all WRP SWCs within the Telephone Company's operating territory at which the customer made a DSL WRP Term Plan commitment, i.e., qualifying in-service lines. Qualifying in-service lines also include any ADSL and SDSL Access Service lines served by any remote SWC that subtends an associated host SWC covered by a DSL WRP Term Plan commitment.

In-service ADSL and SDSL Access Service lines billed under the WRP Monthly Plan are not eligible for the discount under the DSL VPCP and are not counted towards the customer's achievement of its monthly volume commitment.

Available DSL VPCP commitment levels and associated discounts are specified below.

The customer may order the DSL VPCP at the same time it establishes a DSL WRP Term Plan commitment or at any time during the term of an existing DSL WRP Term Plan. In both instances, the DSL VPCP discount and commitment apply during the following twelve months. An Access Order Charge will not apply to establish a new or change an existing DSL VPCP.

Each month on the bill date, the Telephone Company will determine if the DSL WRP Term Plan customer achieved its monthly volume commitment level of qualifying in-service ADSL and SDSL Access Service lines. In any month in which the monthly volume commitment was not met, the Telephone Company will bill the customer a DSL VPCP shortfall charge of \$10.00 per line for each line below its volume commitment level. The following example illustrates the application of the shortfall charge for a DSL WRP Term Plan customer that selected a monthly volume commitment level of 2,500 lines. If on the bill date, the customer had achieved only a total of 2,250 qualifying in-service lines., the Telephone Company would assess a shortfall charge of \$2,500.00 (250 lines x \$10.00 per line). The shortfall charge would be in addition to the applicable discounted billing for the 2,250 qualifying in-service lines.

**RULES AND REGULATIONS FOR
HICKORY TELEPHONE COMPANY'S ADSL**

1. Digital Subscriber Line Access Services (Cont'd)

1.2 DSL Access Services Wholesale Rate Plan (Cont'd)

1.2.1 DSL WRP Term Plan (Cont'd)

(E) DSL Volume Pricing Commitment Plan (Cont'd)

Upon providing thirty (30) days written notice to the Telephone Company, a customer with an existing DSL VPCP will be permitted to increase its existing volume commitment when it establishes a new twelve-month commitment period at a higher volume commitment level. The DSL VPCP discount associated with the higher level of commitment will apply on a prospective basis during the following twelve months

Upon providing thirty (30) days written notice to the Telephone Company, a customer with an existing DSL VPCP will be permitted to terminate its existing volume commitment on a prospective basis as described herein. When the customer elects to terminate its existing DSL VPCP prior to the end of the twelve-month commitment period for any reason, it will be prohibited from establishing a new DSL VPCP commitment with the Telephone Company within the ninety (90) days following such termination. During this 90-day period, the customer will not be eligible for any DSL VPCP discounts. Downgrades from a higher volume commitment level to a lower volume commitment level are treated as terminations subject to the provisions in this paragraph.

Upon providing written notice to the Telephone Company within thirty (30) days prior to the end of its twelve-month DSL VPCP commitment period, the customer may opt to renew, increase or decrease its existing DSL VPCP commitment for the next twelve months. If the customer does not notify the Telephone Company of its election, the customer will not be eligible for the DSL VPCP discount following expiration of its existing commitment period.

**RULES AND REGULATIONS FOR
HICKORY TELEPHONE COMPANY'S ADSL**

DSL Wholesale Rate Plans (WRP)

Proposed Monthly and Term Plan Rates

| <u>Option</u> | <u>Monthly Plan</u> | <u>Option A</u> | | <u>Option B</u> | |
|-------------------------|--------------------------------|------------------------|---------------|------------------------|---------------|
| Monthly Per Wire Center | N/A | \$100.00 | | \$500.00 | |
| Term | N/A | <u>1 Year</u> | <u>3 Year</u> | <u>1 Year</u> | <u>3 Year</u> |
| ADSL | | | | | |
| Voice-Data Option | \$ 29.06 | \$ 20.38 | \$ 16.75 | \$ 15.95 | \$ 11.25 |
| Data-Only Option | \$ 50.51 | \$ 43.38 | \$ 38.40 | \$ 37.95 | \$ 21.25 |

Updated 12/17/09